

SIK PEITZ

Starting Position:

„Cracks repeatedly occurred at the (weld) seam of the downpipe socket in a power plant, which reappeared even after repair.“

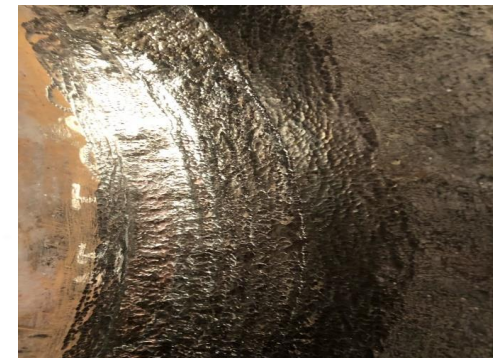
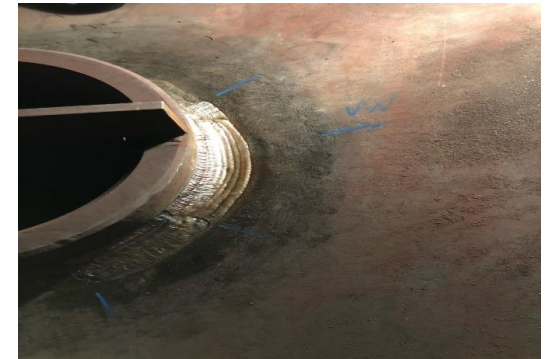
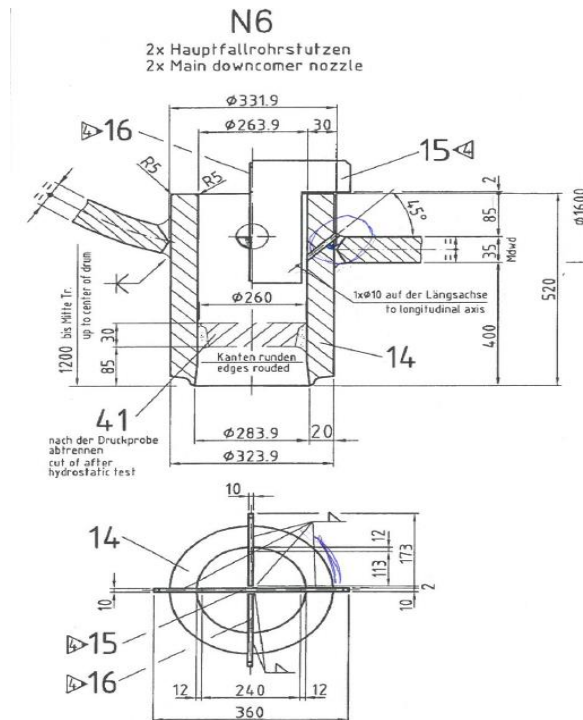
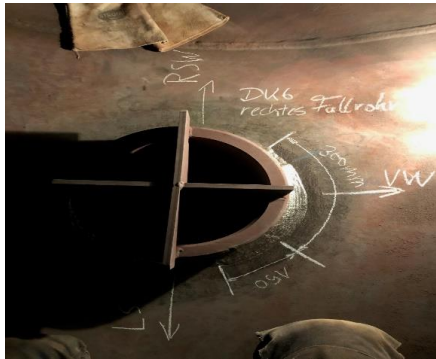

Then followed a PIT treatment of the repair seams:

„After one year of operation, the drum was inspected again and no damage was found in the repair area.“